

Drypower

Rechargeable Lithium LiFePO4

LiFePO4 Battery Model: ML1209

Specifications

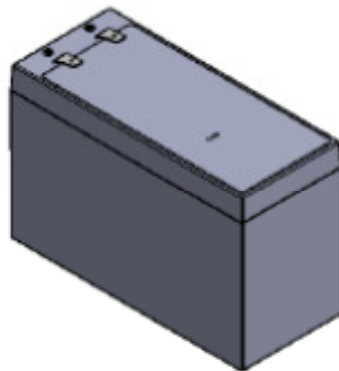

Version	Date	Modification
1.00	13 th March 2014	Draft version
2.00	21 st May 2014	Modified BMS specification

1. Introduction

This battery pack will be a replacement for the standard size 12V 7-9Ah Lead Acid battery.

2. Features

- Premium quality Sony rechargeable Li-FePO4 cell
- No memory effect
- No sulphation
- No gassing
- Low self discharge
- Long life
- High capacity and performance over wide temperature range

Sony 26650FTC1



3. Battery Pack Specifications

Feature	Specifications
Pack configuration	4S3P
Cell manufacturer	Sony
Cell type	26650FTC1
Pack nominal voltage	12.6V
Pack maximum voltage	14.4V
Pack nominal capacity	9Ah
Max. continuous discharge current	25A @25°C
Charge current	2A (8A max.)
Charge Mode	CC-CV
Case	Plastic case (Sabic 6600)
Dimension	150.5*65*97.5mm(L*W*H)
Certification	UN 38.3 tested
Charger	RLF04-20XX or other Drypower approved charger

4. BMS Specifications

No.	Item	Specification	Remark
1	Model	4S-17A	
2	Over charge voltage threshold	$3.8V \pm 25mV/cell$	
3	Over charge voltage release	$3.5V \pm 30mV/cell$	
4	Over discharge voltage threshold	$2.2V \pm 80mV/cell$	
5	Over discharge voltage release	$2.8V \pm 100mV/cell$	
6	Over current protection	$50A \pm 10A$	
7	Over current delay time	256mS	
8	Short circuit protection	$250A \pm 25A$	
9	Balance function	Yes	Charging balance

5. Mechanical drawing

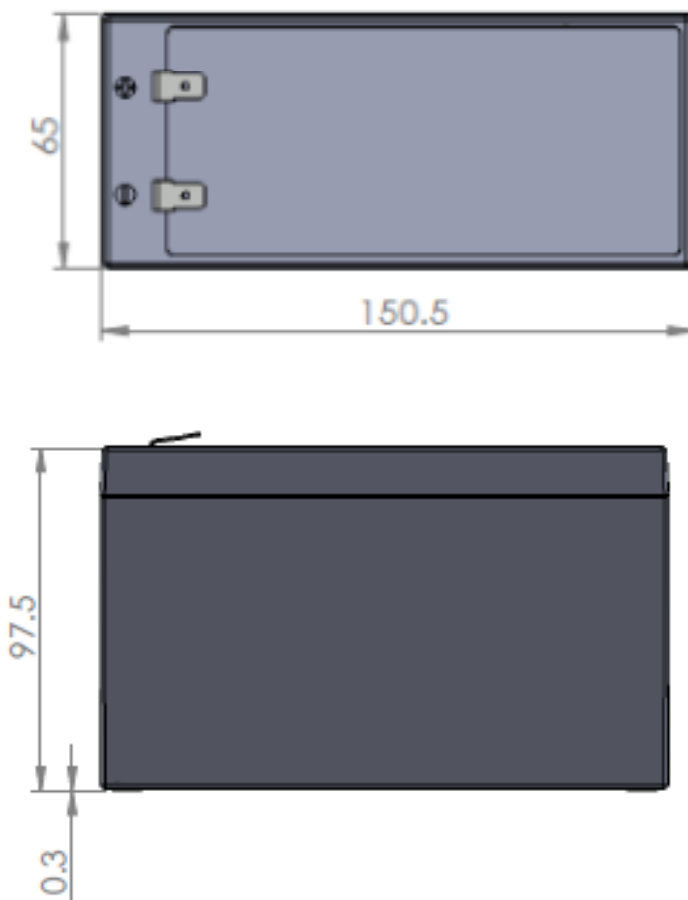

6. Performance Curves

